

Lesson 9.1 • The Theorem of Pythagoras

Name _____ Period _____ Date _____

Give all answers rounded to the nearest 0.1 unit.

1. $a =$ _____

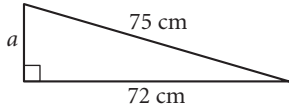

2. $p =$ _____

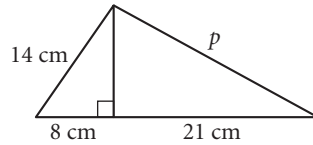

3. $x =$ _____

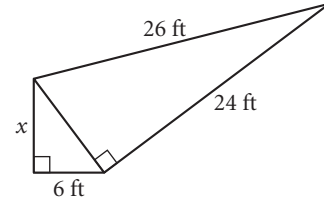

4. Area = 39 in.^2

$h =$ _____

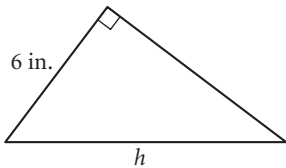

5. Find the area.

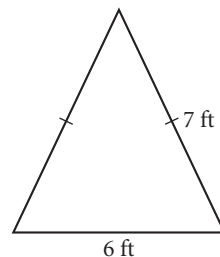

6. Find the coordinates of C and the radius of the circle.

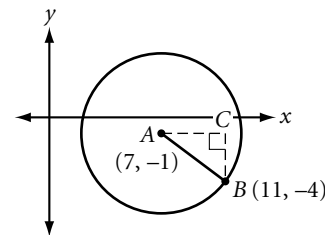

7. Find the length of the diagonal. $P = 68 \text{ cm}$ and $A = 144 \text{ cm}^2$.

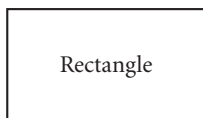

8. Find the area.

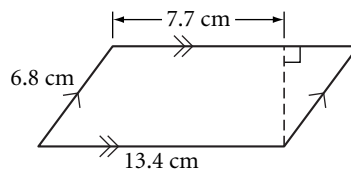

9. $RS = 3 \text{ cm}$. Find RV .

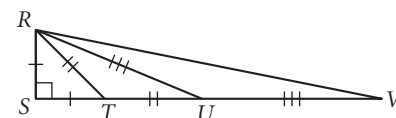

10. A regular decagon is inscribed in a circle with radius 6.7 cm. It has side length 4.14 cm. Find the length of the apothem.

11. Surface area = _____

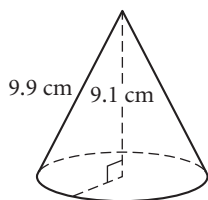

12. Base area = $16\pi \text{ cm}^2$ and slant height = 3 cm. What's wrong with this picture?

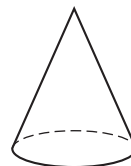

13. Given $\triangle PQR$, with $m\angle P = 90^\circ$, $PQ = 20 \text{ in.}$, and $PR = 15 \text{ in.}$, find the area of $\triangle PQR$, the length of the hypotenuse, and the altitude to the hypotenuse.

14. Find the height of an equilateral triangular pyramid with side length 2 cm.

15. Find the length of the space diagonal of a box with dimensions 40 cm by 55 cm by 32 cm.

Lesson 9.2 • The Converse of the Pythagorean Theorem

Name _____ Period _____ Date _____

All measures are in centimeters. Give answers rounded to the nearest 0.01 cm.

In Exercises 1–7, determine whether or not a triangle with the given side lengths is a right triangle.

1. 76, 120, 98

2. 221, 204, 85

3. $\sqrt{14}$, $\sqrt{30}$, 4

4. $1\frac{2}{3}$, $2\frac{2}{3}$, $3\frac{1}{3}$

5. 5.0, 1.4, 4.8

6. 80, 82, 18

7. 0.5, 1.2, 1.4

8. Determine whether or not A , B , and C are collinear. Explain your method.

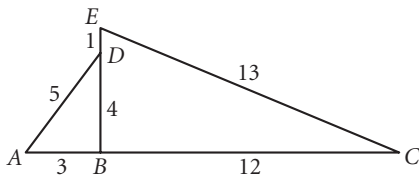

9. What's wrong with this picture?

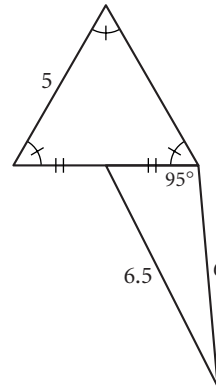

10. Find x . Explain your method.

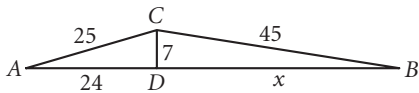

11. Find the area of $ABCD$.

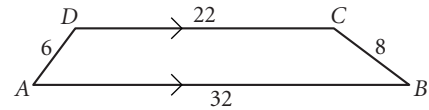

In Exercises 12–16, determine whether or not $ABCD$ is a rectangle. If not enough information is given, write “cannot be determined.”

12. $AB = 3$, $BC = 4$, and $AC = 5$.

13. $AB = 3$, $BC = 4$, and $AC = 6$.

14. $AB = 3$, $BC = 4$, $DA = 4$, and $AC = 5$.

15. $AB = 3$, $BC = 4$, $CD = 3$, $DA = 4$, and $AC = BD$.

16. $AB = 3$, $BC = 4$, $CD = 3$, $AC = 5$, and $BD = 5$.

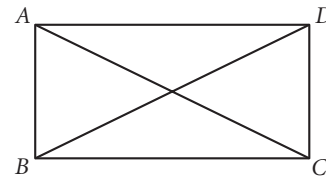

Lesson 9.3 • Two Special Right Triangles

Name _____ Period _____ Date _____

Give your answers in exact form unless otherwise indicated.

For Exercises 1 and 2, refer to $\triangle ABC$.

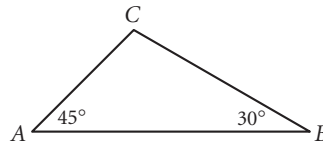

- If $BC = 60$, then $AC = \underline{\hspace{2cm}}$, $AB = \underline{\hspace{2cm}}$, and area $\triangle ABC = \underline{\hspace{2cm}}$.
- If $BC = 60\sqrt{2}$, then $AC = \underline{\hspace{2cm}}$, $AB = \underline{\hspace{2cm}}$, and area $\triangle ABC = \underline{\hspace{2cm}}$.

- Find the perimeter and area of $KLMN$.

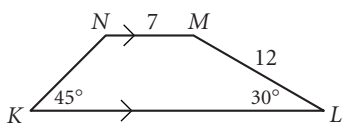

- $\triangle ABC$ is equilateral. $AB = 18$. Find the area of $ABDE$.

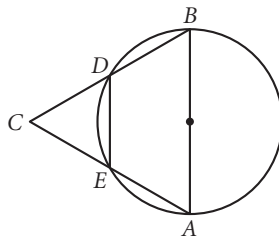

- Find the area in terms of p , q , and r .

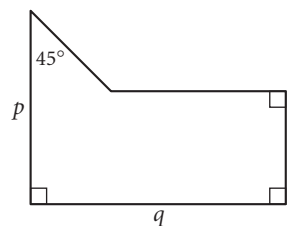

- Find the area of an isosceles trapezoid if the bases have lengths 12 and 17 and the base angles have measure 60° .

In Exercises 7 and 8, find the coordinates of C .

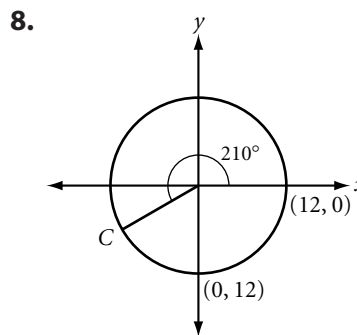
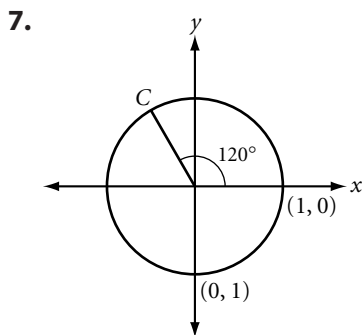

- Construct a segment with length $2\sqrt{3}(AB)$.
- Construct a square with area $5(AB)^2$.
- Find the area of an 8-pointed star inscribed in a circle with radius 10 ft. Round your answer to two decimal places.

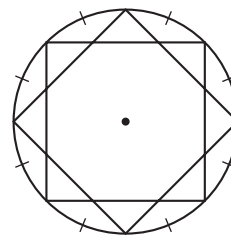

Lesson 9.4 • Story Problems

Name _____ Period _____ Date _____

1. A 20 ft ladder reaches a window 18 ft high. How far is the foot of the ladder from the base of the building? How far must the foot of the ladder be moved to lower the top of the ladder by 2 ft?
2. Robin and Dovey have four pet pigeons that they train to race. They release the birds at Robin's house and then drive to Dovey's to collect them. To drive from Robin's to Dovey's, because of one-way streets, they go 3.1 km north, turn right and go 1.7 km east, turn left and go 2.3 km north, turn right and go 0.9 km east, turn left and go 1.2 km north, turn left and go 4.1 km west, and finally turn left and go 0.4 km south. How far do the pigeons have to fly to go directly from Robin's house to Dovey's house?
3. Hans needs to paint the 18-in.-wide trim around the roof eaves and gable ends of his house with 2 coats of paint. A quart can of paint covers 175 ft^2 and costs \$9.75. A gallon can of paint costs \$27.95. How much paint should Hans buy? Explain.

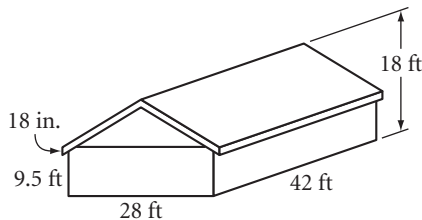

4. Ethel Diggs is at her base camp. She walks 3 km at a bearing of 50° . She turns and walks 4 km, and then turns and walks 5 km. She finds herself back at camp. What were the possible bearings of her 4 km leg?

Lesson 9.5 • Distance in Coordinate Geometry

Name _____ Period _____ Date _____

For Exercises 1 and 2, use $\triangle ABC$ with coordinates $A(4, 14)$, $B(10, 6)$, and $C(16, 14)$.

1. Determine whether $\triangle ABC$ is scalene, isosceles, or equilateral. Find the perimeter of the triangle.
2. Find the midpoints M and N of \overline{AB} and \overline{AC} respectively. Find the slopes and lengths of \overline{MN} and \overline{BC} . How do the slopes compare? How do the lengths compare?

In Exercises 3–8, use the distance formula and the slope of segments to identify the type of quadrilateral. Explain your reasoning.

3. $A(-2, 1)$, $B(3, -2)$, $C(8, 1)$, $D(3, 4)$
4. $P(-2, 7)$, $Q(-3, -2)$, $R(6, -1)$, $S(7, 8)$
5. $K(7, 3)$, $L(0, 2)$, $M(-1, -5)$, $N(7, -5)$
6. $E(4, 0)$, $F(16, 4)$, $G(7, 7)$, $H(-5, 3)$
7. $W(17, -6)$, $X(9, 3)$, $Y(0, -5)$, $Z(8, -14)$
8. $T(-3, -3)$, $U(4, 4)$, $V(0, 6)$, $W(-5, 1)$
9. Find the equation of the circle whose diameter has endpoints $(4, -6)$ and $(-4, 0)$.
10. P is the center of the circle. What's wrong with this picture?

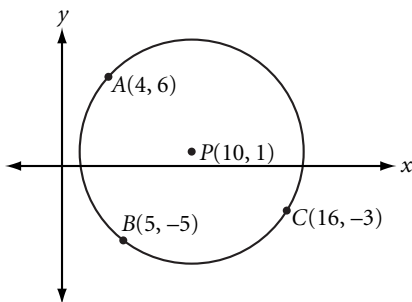

11. Given circle O with $O(3, -4)$ and radius 5, find 12 points on the circle with integer coordinates.

Lesson 9.6 • Circles and the Pythagorean Theorem

Name _____ Period _____ Date _____

1. $AO = 7$. $AC = 8$. Find CB .

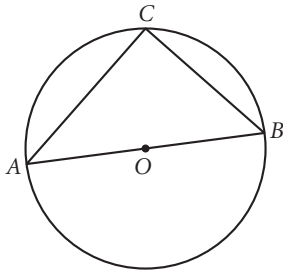

2. What's wrong with this picture?

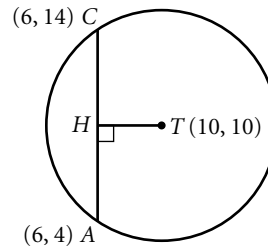

3. $MQ = 9$. $PS = 4$. Find PT , PT^2 , and $(PS \cdot PQ)$. Explain why, in general, $PT^2 = PS \cdot PQ$.

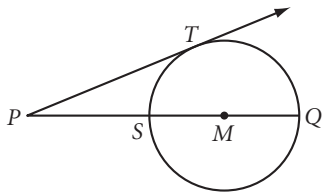

4. $AP = 63$ cm. Radius of circle $O = 37$ cm. How far is A from the circle?

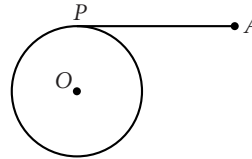

5. Two perpendicular chords with lengths 12.2 cm and 8.8 cm have a common endpoint. What is the area of the circle?
6. $ABCD$ is inscribed in a circle. \overline{AC} is a diameter. If $AB = 9.6$, $BC = 5.7$, and $CD = 3.1$, find AD .
7. \overline{AB} is a diameter, $AB = 8$, $AQ = 4$, and $AP = 8$. Find PR and PB .

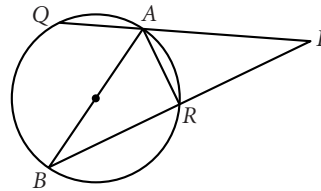

8. Find ST .

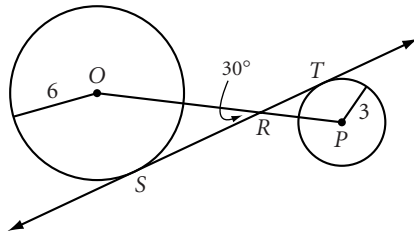

9. Find ST .

